

CERACOATS

WE MAKE IT POSSIBLE

MFGR. OF GLASS LINED EQUIPMENTS



ABOUT US

- We are a team of proficient Glass Lining experts with decades of experience in manufacturing Glass lining Equipment for application in highly aggressive duty condition in the chemical and pharmaceutical industries.
- It is the specializing in manufacturing Glass Lined Reactor, Glass Lined Storage Tank (Vertical & Horizontal), Glass Lined Columns and other Glass lined chemical Equipment.
- Members of management team are mentor of the company **Mr. Ambalal Patel** a veteran industrialist and a maven of Glass Lining Technology with an experience of close to 5 decades in the Glass lining field and his dynamic son **Mr. Tanmay Patel** and his proficient partner **Mr. Chirayu Patel**. We are reared to offer cutting edge solution for the Chemical, Pharmaceutical, Agro Chemical, Food Processes, Speciality Fine Chemical, Pigment types industry.
- Ceracoats strode into new era with a relatively high-minded growth plan to provide a complete range of Glass Lined Equipment, Spares item, Accessories under one roof.
- Our mission is the offer the most reliable Glass Lined Equipment meeting customer requirement for chemical industry and meeting all the statutory requirement for the pharmaceutical industry with our range of cGMP Equipment.
- Ceracoats manufacturing facility is located at prime highway of smart cities Anand, Ahmedabad and Vadodara with an easy access to transport facilities.



OUR MISSION

Providing the pharmaceutical and chemical industry with technological solutions optimised in terms of quality, reliability, safety, cleanability and energy consumption. Always a step ahead.



OUR VISION

To be the best choice for our Customers, supplying tailored products with the Excellent Quality, Safety and the latest technology with competitive solutions and flexible time schedule.

CERACOATS is an iconic name in the Glass Lined industry. The main principles always remained the same: simplicity, clarity, and quality. The emblem got a new color — now it is cobalt blue, a color of hope, reliability, and loyalty. The new color palette made the logo fresher and younger, now it evokes a sense of dynamics and energy



FACILITIES OF FABRICATION AND MANUFACTURING UNITS:

Total land Area: 118926 Sq. Ft

Shop Floor Area: 50000 Sq. Ft

- » POWER CONNECTION: 1000 KVA
- » 480 KW BOOGIE FURNACE (FOR COLUMNS, GLRS & PIPES & FITTINGS) – 01 No.
- » 400 KW FURNACE WITH MONORAIL SYSTEM (CAPABLE OF HANGING 36 AGITATORS & BAFFLES) – 01 No.
- » 100 KW FURNACE WITH MANIPULATOR (FOR PIPES & FITTINGS) – 01 No.
- » 50 KW FURNACE (FOR VALVES, PIPES & FITTINGS) – 01 No.
- » 35 KW FURNACE (FOR PIPES & FITTINGS) – 01 No.
- » 35 KW FURNACE (FOR SPINDLES) – 01 No.
- » 18 KW LOCAL FURNACES – 05 Nos.
- » OVERHEAD CRANES: 5 TN – 02 Nos., 3 TN – 02 Nos., 2 TN – 01 Nos. (TOTAL 05 Nos.)
- » COMPRESSORS: 50 HP – 03 Nos., 10 HP – 01 No.
- » COMPRESSORS: 15 HP – 01 No., 10 HP – 01 No., 5 HP – 01 No.
- » WELDING MACHINES: 07 Nos.
- » LATHE MACHINE: 05 Nos.
- » GRINDERS: 20 Nos.
- » BLASTING UNIT: 5 MTR X 4 MTR X 3.5 MTR – 01 No.
- » PAINT BOOTH: 5 MTR X 5 MTR X 7 MTR – 01 No.
- » PRESS FOR PTFE MOULDING 400 Tn – 01 No.
- » 25 KW SINTERING FURNACE FOR PTFE BUSH & VALVE SEATS: 01 No.
- » MS DIE FOR PTFE MOULDING: 25 NB TO 600 NB
- » ROTARY FURNACES: 05 Nos.
- » ROTARY CONE MIXER: 02 Nos.
- » BALL MILL – 03 Nos.

PRODUCT RANGE:

The CERACOATS range consists of both ready-made and custom built equipment and accessories of versatile nature. The includes an impressive array of Glass lined Reactors, Process Tank, Evaporation Vessel, Distillation Column, Mixer and Agitator, Heat Exchanger, Pipes-fittings and valves.

Reactors (Standard & cGMP) Customized	Type AE DIN 28136	63 to 6300 Ltrs.
	Type CE DIN 28136	1600 to 6300 Ltrs.
AE Type Receivers (Jacketed / Unjacketed)	Vertical	AE-63 Ltrs. to AE-6300 Ltrs.
CE Type Receivers (Jacketed / Unjacketed)		160 to 6300 Ltrs.
	Horizontal	1000 to 5000 Ltrs
Agitating system	Anchor agitator Impeller agitator Impeller cum pitch blade agitator CBRT agitator Hydro foil agitator Twin level impeller agitator Twin level pitch blade agitator	Up to 32000 Ltrs
	Thermowell / baffle	Up to 32000 Ltrs
Condensers & Heat exchangers	Plate type	4 to 10 Sq. Mtr.
	Shell in Shell	2 to 10 Sq. Mtr
Columns	Distillation	250 to 1400 mm dia
Valves	Bottom Outlet Valve Gland Type Bellow Sealed type	80 NB x 50 NB
		100 NB x 80 NB
		150 NB x 100 NB
	Diaphragm Valve	25 NB - 150 NB
Pipes	Unjacketed	25 to 500 NB
	Jacketed	80 to 500 NB
Fittings (Jacketed / Unjacketed)	LR bends, Cross tee etc.	Up to 500 NB

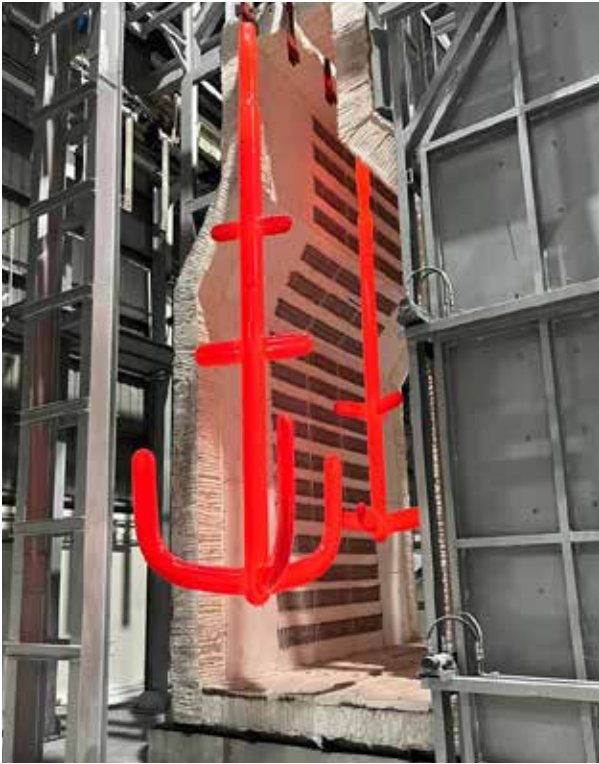

MSGL FLANGED TYPE AE REACTOR

GLASS-LINED JACKETED REACTORS, TWO-PIECE CONSTRUCTION WITH CLAMPED COVER IN ACCORDANCE WITH DIN 28136	
Standard sizes:	63-6300 Ltrs.
Design Pressure:	Pressure : -1/+6 Kg/cm ² in the inner vessel -1/+6 Kg/cm ² in the Jacket.
Design Temperature:	-25/+200°C.
Raw Material & welding consumables :	As per ASME Section-II, Part - A & C
Fabrication & welding	As per ASME Section - VIII, Div-1, ASME Section- IX
NDT :	As per ASME Section-V and ASME Section-VIII
Glass – lining:	<ul style="list-style-type: none"> • High voltage spark test after glass-lining; at 20000V; • Before shipment: at 10000V.
Agitating system:	<ul style="list-style-type: none"> • Standard version with anchor agitator and thermowell. • As an alternative impeller agitator and baffle can be Supplied. Pitched blade or axial propeller can also be Installed for specific needs. • Drive unit consisting of an asynchronous three phase Explosion-proof motor, gear-box. • Lantern stool houses self-aligning double ball-bearing and Specially designed two-piece muff coupling for perfect Alignment. • Direct coupled geared motor is also provided as an Alternative.
Agitator speed:	<ul style="list-style-type: none"> • 48 RPM for Anchor Agitator, 96 RPM for Impeller Agitator. • On Request, We can Supply aTwo-Speed Version Motor or on Electronic Speed Variator. • Mechanical seal is Available in two Alternative and Perfectly Interchangeable Versions. • Single Mechanical Seal, Double Mechanical Seal complete with Suitable Lubrication and Counter-Pressure System. • Drive Unit is Designed to Facilitate Easy and Quick Replacement of Component without Disturbing Alignment or Dismantling of Major Drive Components.
Supports:	<ul style="list-style-type: none"> • Both - legs and brackets. • On request, other supports can be provided.
	<p>Accessories included in the supply:</p> <ul style="list-style-type: none"> • Glasslined manhole protection ring • sight - glass unit and light glass • loose flanges for operating nozzles • glasslined bottom outlet valve • spring loaded device for opening of manhole cover
	<p>Accessories available on request:</p> <ul style="list-style-type: none"> • Tantalum Tip With Rtd Sensor for Temperature Measurement • PTFE Lined Dip Pipe / Sparger • Illumination Explosion - Proof Type Lamp • Agitation Nozzles on Jacket • Electronic Variable Speed Drive



AE TYPE MSGL REACTOR

MSGL FLANGED TYPE AE REACTOR

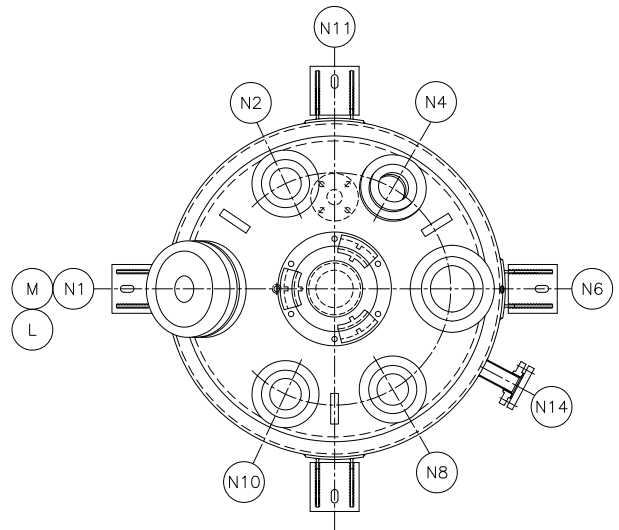
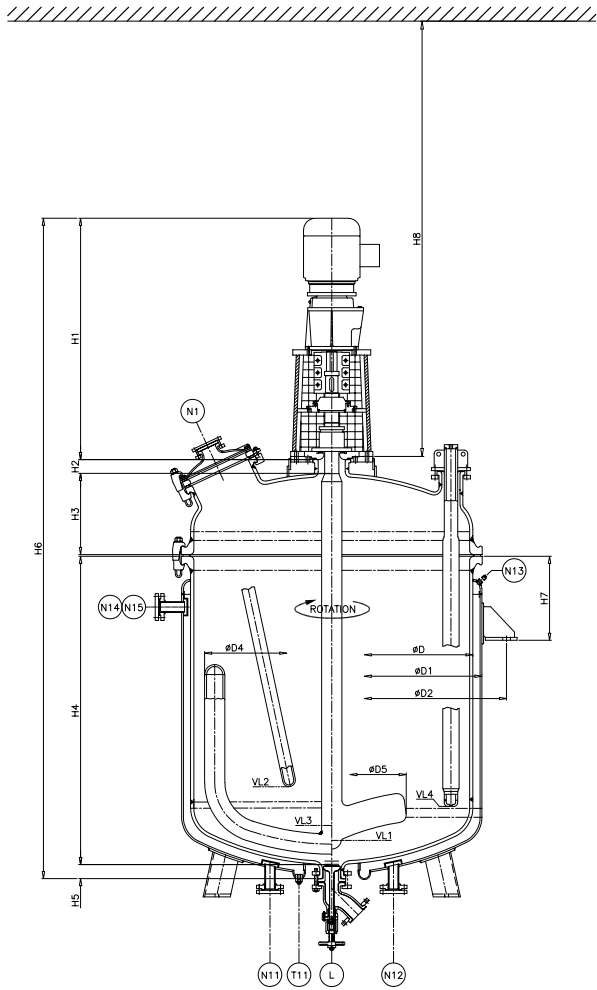

NOZZLE ORIENTATION
 AE-63L TO AE-630L

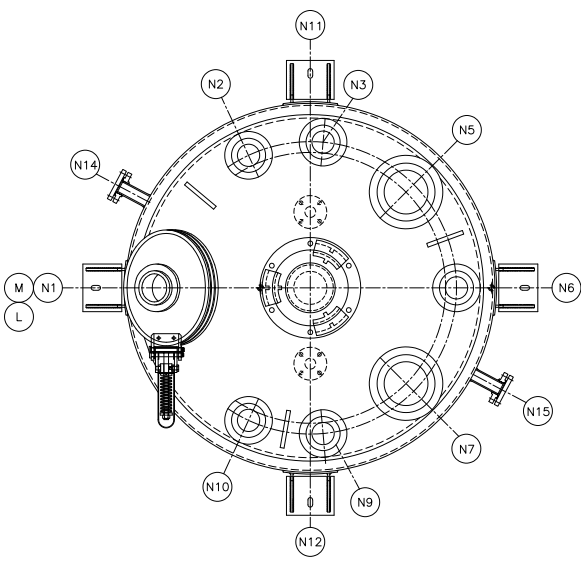

NOZZLE ORIENTATION
 AE-1000L TO AE-3000L

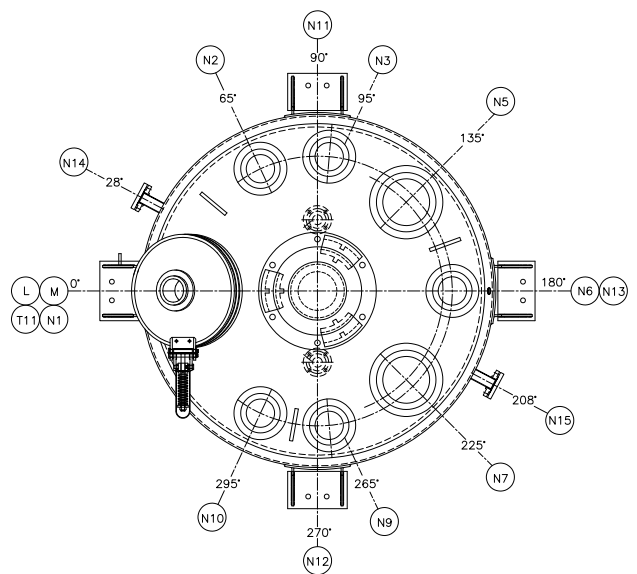

NOZZLE ORIENTATION
 AE-4000L TO AE-6300L

MSGL FLANGED TYPE AE REACTOR

GROSS VOLUME (LTRS.)	63	100	160	250	500	630	1000	1600	2000	2500	3000	4000	5000	6300
TOTAL VOLUME (LTRS.)	93	135	250	340	730	855	1470	2300	2580	3500	3800	5385	6800	8200
JACKET VOLUME (LTRS.)	22	33	71	95	150	165	210	287	340	375	455	522	560	630
VL1 (LTRS.) MIN. STIRRABLE VOLUME (ANCHOR)	6	6	15	15	32	32	35	60	60	69	69	102	117	130
VL2 (LTRS.) MIN.SENSIBLE VOLUME	34	34	72	90	204	204	305	465	465	604	634	900	773	1150
VL3 (LTRS.) MIN.STIRRABLE VOLUME (IMPELLER)	12	12	32	32	62	62	78	150	150	126	126	250	242	310
VL4 (LTRS.) MIN.SENSIBLE VOLUME	19	19	64	85	87	87	102	215	215	277	282	326	1132	1160
APPRX.HEAT SURFACE AREA (Sq.Mtr)	0.6	0.9	1.2	1.8	2.7	3.1	4.6	6.2	7.3	8.3	9.3	11.7	13	16.60
ØD	508	508	800	800	1000	1000	1200	1400	1400	1600	1600	1800	2000	2000
ØD1	600	600	900	900	1100	1100	1300	1500	1500	1700	1700	1900	2100	2100
ØD2	756	756	1056	1056	1355	1355	1559	1780	1780	1980	1980	2210	2414	2414
ØD4	420	420	670	670	880	880	1060	1250	1250	1440	1440	1630	1810	1810
ØD5	300	300	480	480	600	600	720	840	840	960	960	1100	1100	1100
H1	830	830	1030	1030	1075	1075	1075	1285	1285	1350	1350	1577	1700	1700
H2	70	70	90	90	90	90	90	100	100	100	100	130	130	130
H3	180	180	280	280	300	300	350	400	400	460	460	500	550	550
H4	400	600	522	714	845	1000	1200	1400	1600	1600	1755	2000	2000	3060
H5	70	70	70	70	78	78	76	80	80	80	80	80	86	86
H6	1560	1760	2000	2190	2395	2550	2800	3272	3472	3598	3750	4297	4476	4976
H7	300	300	320	360	405	432	432	475	475	485	485	630	640	640
H8	1600	1600	1600	1830	1830	1830	1880	1720	1790	1820	1920	2000	2030	2050
DRAIN VALVE	80 x 50	80 x 50	100 x 80	100 x 80	100 x 80	100 x 80	100 x 80	100 x 80	100 x 80	100 x 80	100 x 80	100 x 80	150 x 100	150 x 100
MOTOR (H.P)	1	1	2	2	3	3	3	5	5	7.5	7.5	10	15	15
WEIGHT (~ Kg)	445	500	935	1038	1532	1630	2122	2835	3014	3631	3800	5572	6190	6924

NOZZLE

GROSS VOLUME (LTRS.)	63	100	160	250	500	630	1000	1600	2000	2500	3000	4000	5000	6300
N1	100	100	150	150	250	250	350 x 450	350 x 450	350 x 450	350 x 450	350 x 450	500	500	500
N2,N10	40	40	50	50	100	100	100	100	100	100	100	150	150	150
N3	-	-	-	-	-	-	100	100	100	100	100	150	150	150
N4	80	80	80	80	100	100	-	-	-	-	-	-	-	-
N5,N7	-	-	-	-	-	-	200	200	200	200	200	250	250	250
N6	80	80	80	80	150	150	100	100	100	100	100	150	150	150
N8	50	50	80	80	100	100	-	-	-	-	-	-	-	-
N9	-	-	-	-	-	-	100	100	100	100	100	150	150	150
M	50	50	80	80	125	125	125	150	150	150	150	200	200	200
L	80	80	100	100	100	100	100	100	100	100	100	100	150	150
N11	40	40	40	40	50	50	50	50	50	50	50	50	80	80
N12	-	-	-	-	-	-	-	50	50	50	50	50	80	80
N14	40	40	40	40	50	50	50	50	50	50	50	50	80	80
N15	-	-	-	-	-	-	-	50	50	50	50	50	80	80
N13,T11	1/2" BSP	1/2" BSP	1/2" BSP	1/2" BSP	1/2" BSP	1/2" BSP	1/2" BSP	1/2" BSP	1/2" BSP	1/2" BSP	1/2" BSP	1/2" BSP	1/2" BSP	1/2" BSP

MSGL MONOBLOCK TYPE CE REACTOR

GLASS - LINED JACKETED REACTORS, ONE-PIECE CONSTRUCTION WITH LARGE CENTRAL OPENING COVER FOR AGITATOR ENTRY IN ACCORDANCE WITH DIN 28136:

Standard sizes:	1600-6300 Lts.
Design Pressure:	Pressure: -1 / + 6 Kg/cm ² in the inner vessel -1 / + 6 Kg/cm ² in the jacket
Design Temperature:	-25 / + 200 ° C.
Raw Material & welding consumables :	As per ASME Section-II, Part - A & C
Fabrication & welding	As per ASME Section - VIII, Div-1, ASME Section- IX
NDT :	As per ASME Section-V and ASME Section-VIII
Spark Test	<ul style="list-style-type: none"> • High voltage spark test after glasslining; at 20000V. • Before shipment: at 10000V.
Agitating system:	<ul style="list-style-type: none"> • Standard version with Impeller Agitator and Thermowell cum Baffle • As an alternative Pitched Blade / Axial propeller / Twin level Agitator can also be Installed for specific needs. • Drive unit consisting of an asynchronous three phase Explosion-proof motor, gear-box. • Lantern stool houses self-aligning double ball-bearing and Specially designed two-piece muff coupling for perfect Alignment. • Direct coupled geared motor is also provided as an Alternative.
Agitator Speed	<ul style="list-style-type: none"> • 96 RPM for Impeller Agitator. • On request, we can supply a two-speed version motor or on Electronic speed variator. • Mechanical seal is available in two alternative and Perfectly interchangeable versions. • Single Mechanical seal, Double Mechanical Seal complete with Suitable Lubrication and counter-pressure system. • Drive Unit is Designed to Facilitate Easy and Quick Replacement of Component without Disturbing Alignment or Dismantling of Major Drive Components.
Supports:	<ul style="list-style-type: none"> • Both - Legs and Brackets. On Request, other Supports can be Provided.
Accessories included in the supply:	<ul style="list-style-type: none"> • Glasslined Manhole Protection Ring • Sight Glass Unit and Light Glass • Loose Flanges for Operating Nozzles • Glasslined Bottom Outlet Valve • Spring Loaded Device for Opening of Manhole Cover
Accessories available on request:	<ul style="list-style-type: none"> • Tantalum Tip With Rtd Sensor for Temperature Measurement • PTFE Lined Dip Pipe / Sparger • Illumination Explosion - Proof Type Lamp • Agitation Nozzles on Jacket • Electronic Variable Speed Drive



CE TYPE MSGL REACTOR

MSGL MONOBLOCK TYPE CE REACTOR

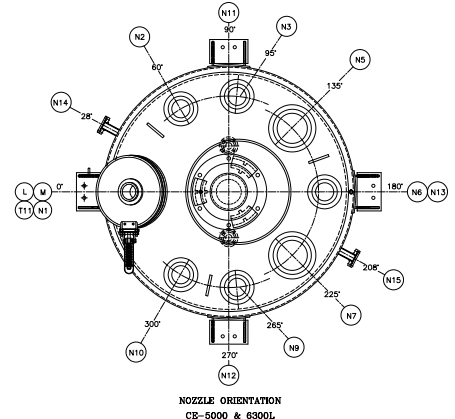
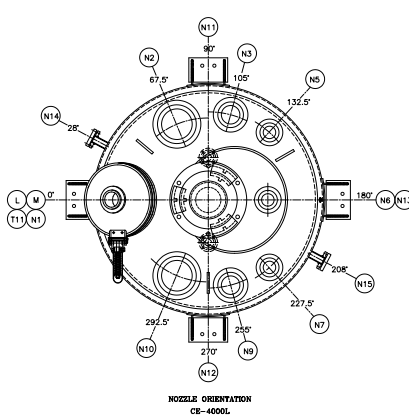
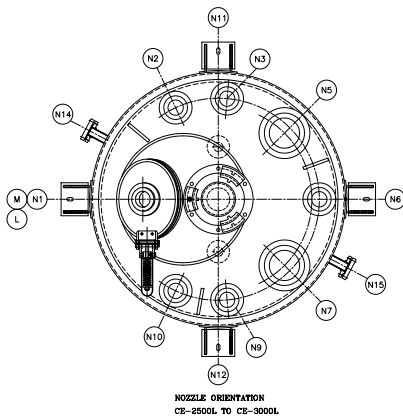
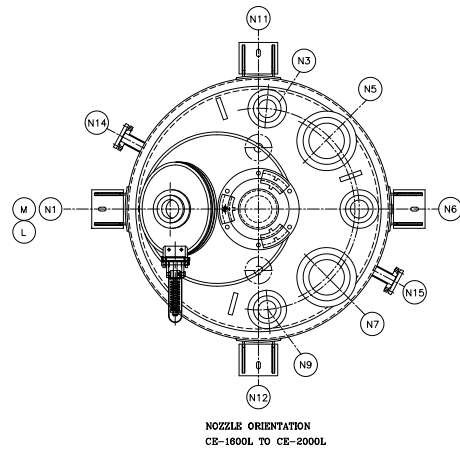
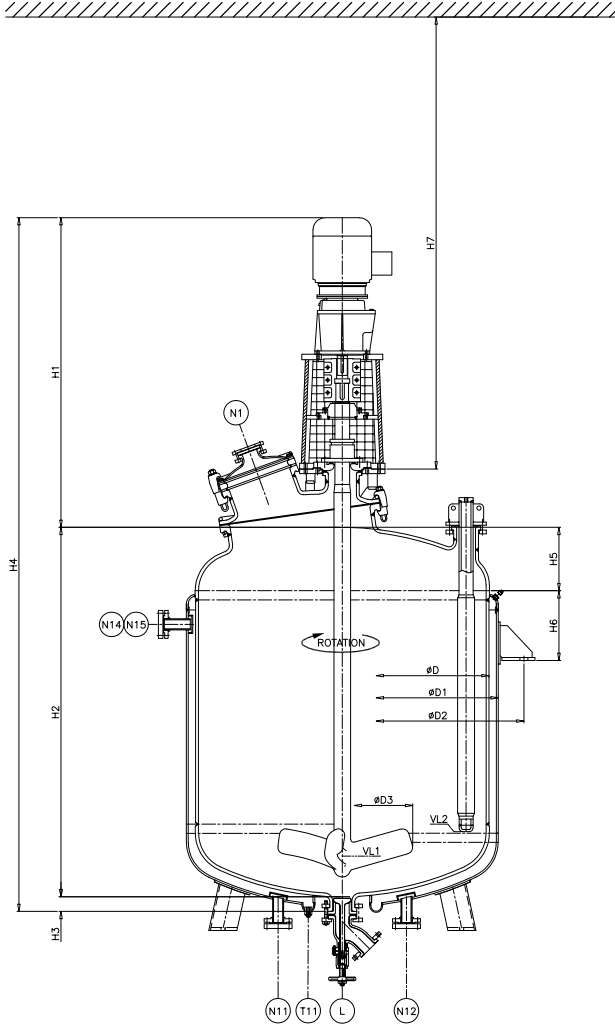

MSGL MONOBLOCK TYPE CE REACTOR

GROSS VOLUME (LTRS.)	1600	2000	2500	3000	4000	5000	6300
TOTAL VOLUME (LTRS.)	2045	2360	3100	3400	4920	6060	7595
JACKET VOLUME (LTRS.)	320	355	415	455	570	552	755
VL1 (LTRS.) MIN. STIRRABLE VOLUME (IMPELLER)	115	115	195	195	195	210	210
VL2 (LTRS.) MIN. SENSIBLE VOLUME	205	205	244	244	337	412	412
~ HEAT SURFACE AREA (Sq.Mtr)	6.5	7.5	8.6	10	12	13.4	16.6
ØD	1400	1400	1600	1600	1800	2000	2000
ØD1	1500	1500	1700	1700	1900	2100	2100
ØD2	1780	1780	1980	1980	2210	2414	2414
ØD3	840	840	960	960	1100	1100	1100
H1	1585	1585	1700	1700	1900	2100	2100
H2	1611	1811	1859	2014	2297	2325	2840
H3	80	80	80	80	80	86	86
H4	3311	3511	3639	3794	4287	4341	4856
H5	285	285	344	344	372	424	424
H6	380	380	380	380	545	535	535
H7	1580	1590	1600	1730	1950	2350	2650
DRAIN VALVE	100 x 80	100 x 80	100 x 80	100 x 80	100 x 80	150 x 100	150 x 100
DRIVE POWER (H.P)	5	5	7.5	7.5	10	15	15
TARE WEIGHT (~Kg)	2682	2860	3437	3606	5241	5756	6500

NOZZLE

GROSS VOLUME (LTRS.)	1600	2000	2500	3000	4000	5000	6300
N1	350 x 450	350 x 450	350 x 450	350 x 450	500	500	500
N2,N10	-	-	100	100	250	150	150
N3	100	100	100	100	150	150	150
N4	-	-	-	-	-	-	-
N5,N7	200	200	200	200	100	250	250
N6	100	100	100	100	100	150	150
N8	-	-	-	-	-	-	-
N9	100	100	100	100	150	150	150
M	150	150	150	150	200	200	200
L	100	100	100	100	100	150	150
N11,N12	50	50	50	50	50	80	80
N14,N15	50	50	50	50	50	80	80
N13,T11	1/2" BSP	1/2" BSP	1/2" BSP	1/2" BSP	1/2" BSP	1/2" BSP	1/2" BSP

MSGL AE TYPE VERTICAL STORAGE TANK

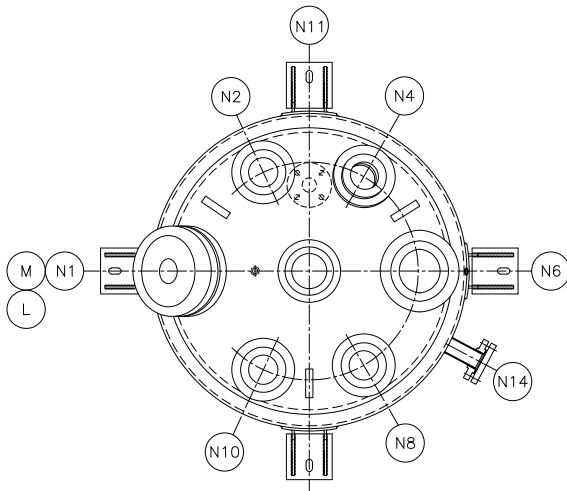
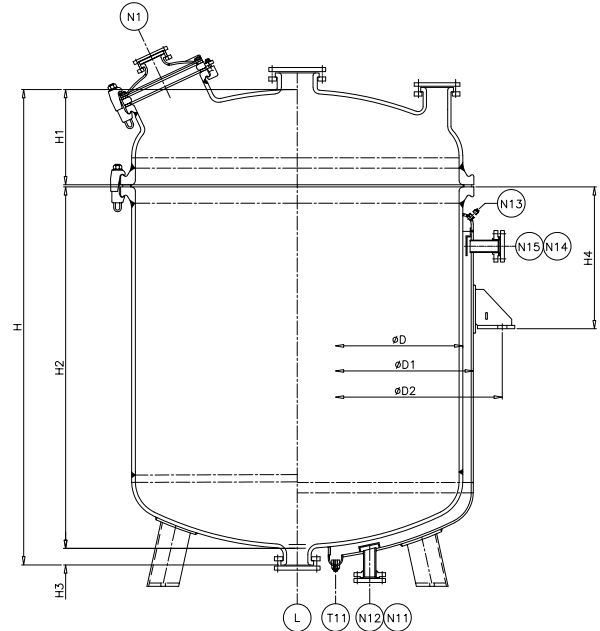
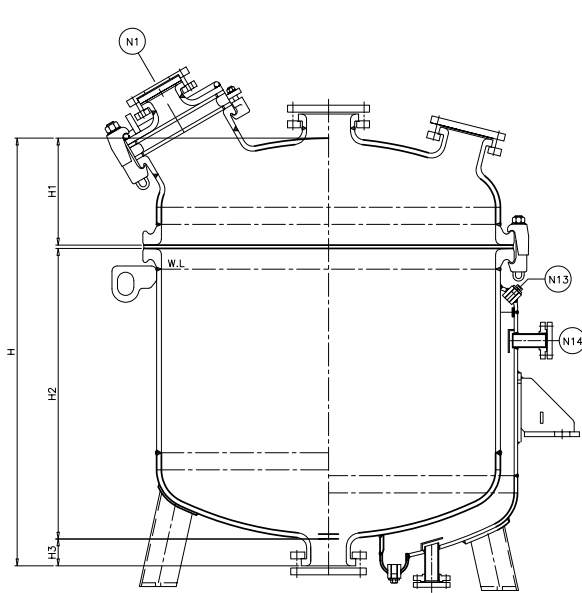

NOZZLE ORIENTATION
 AE-63L TO AE-630L

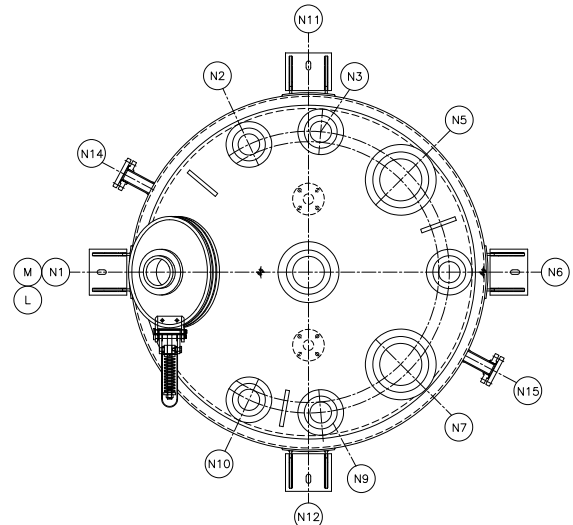

NOZZLE ORIENTATION
 AE-1000L TO AE-3000L

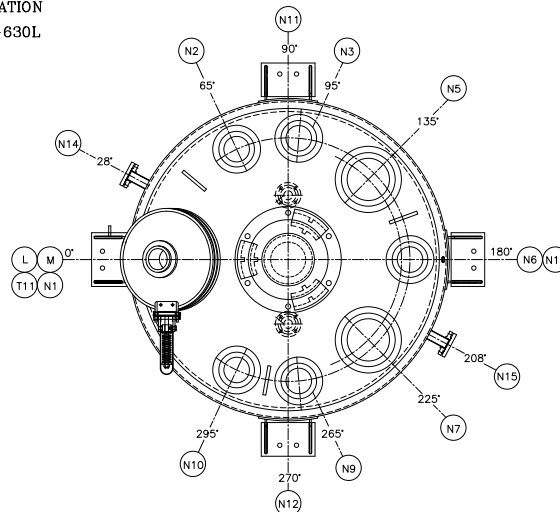

NOZZLE ORIENTATION
 AE-4000L TO AE-6300L

AE TYPE MSGL JACKETED / UNJACKETED TANK

GROSS VOL. (LTRS.)	63	100	160	250	500	630	1000	1600	2000	2500	3000	4000	5000	6300
TOTAL VOL. (LTRS.)	93	135	250	340	730	855	1470	2300	2580	3500	3800	5385	6800	8200
JACKET VOL. (LTRS.)	22	33	71	95	150	165	210	287	340	375	455	522	560	630
HEAT SURFACE AREA (Sq.Mtr)	0.6	0.9	1.2	1.8	2.7	3.1	4.6	6.2	7.3	8.3	9.3	11.7	13	16.60
ØD	508	508	800	800	1000	1000	1200	1400	1400	1600	1600	1800	2000	2000
ØD1	600	600	900	900	1100	1100	1300	1500	1500	1700	1700	1900	2100	2100
ØD2	756	756	1056	1056	1355	1355	1559	1780	1780	1980	1980	2210	2414	2414
H1	180	180	280	280	300	300	350	400	400	460	460	500	550	550
H2	400	600	522	714	845	1000	1200	1400	1600	1600	1755	2000	2000	3060
H3	70	70	70	70	78	78	76	80	80	80	80	80	86	86
H	650	850	872	1064	1223	1378	1626	1880	2080	2140	2295	2580	2636	3696
WEIGHT (~ Kg) Jacketed	330	381	720	816	1250	1345	1785	2276	2446	2940	3102	4516	5030	5738
WEIGHT (~ Kg) UnJacketed	305	340	562	648	985	1065	1365	1716	1815	2210	2315	3286	3820	4273

NOZZLES

GROSS VOL. (LTRS.)	63	100	160	250	500	630	1000	1600	2000	2500	3000	4000	5000	6300
N1	100	100	150	150	250	250	350 x 450	350 x 450	350 x 450	350 x 450	350 x 450	500	500	500
N2,N10	40	40	50	50	100	100	100	100	100	100	100	150	150	150
N3	-	-	-	-	-	-	100	100	100	100	100	150	150	150
N4	80	80	80	80	100	100	-	-	-	-	-	-	-	-
N5,N7	-	-	-	-	-	-	200	200	200	200	200	250	250	250
N6	80	80	80	80	150	150	100	100	100	100	100	150	150	150
N8	50	50	80	80	100	100	-	-	-	-	-	-	-	-
N9	-	-	-	-	-	-	100	100	100	100	100	150	150	150
M	50	50	80	80	125	125	125	150	150	150	150	200	200	200
L	80	80	100	100	100	100	100	100	100	100	100	100	150	150
N11	40	40	40	40	50	50	50	50	50	50	50	50	80	80
N12	-	-	-	-	-	-	-	50	50	50	50	50	80	80
N14	40	40	40	40	50	50	50	50	50	50	50	50	80	80
N15	-	-	-	-	-	-	-	50	50	50	50	50	80	80
N13,T11	1/2" BSP	1/2" BSP	1/2" BSP	1/2" BSP	1/2" BSP	1/2" BSP	1/2" BSP	1/2" BSP	1/2" BSP	1/2" BSP	1/2" BSP	1/2" BSP	1/2" BSP	1/2" BSP

CE TYPE VERTICAL STORAGE TANK

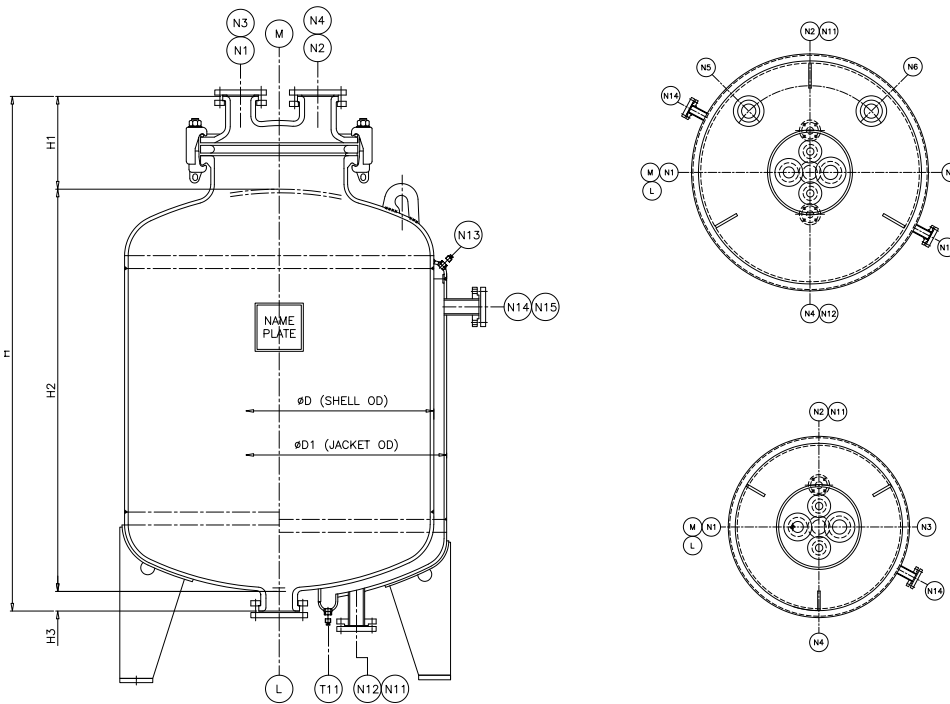

MONOBLOCK TYPE JACKETED / UNJACKETED VERTICAL RECEIVER

GROSS VOL. (LTRS.)	160	250	500	630	1000	1600	2000	2500	3000	4000	5000	6300
TOTAL VOL. (LTRS.)	240	340	730	900	1470	2060	2385	3100	3400	4920	6598	7595
JACKET VOL. (LTRS.)	71	95	135	160	210	278	355	415	455	570	602	755
HEAT SURFACE AREA (M ²)	1.2	2.15	3.67	3.97	6	6.5	7.25	8.6	10	12	14.2	16.6
ØD	800	800	1000	1000	1200	1400	1400	1600	1600	1800	2000	2000
ØD1	900	900	1100	1100	1300	1500	1500	1700	1700	1900	2100	2100
H1	300	330	355	355	355	355	355	355	355	355	355	355
H2	850	1000	1155	1355	1560	1610	1810	1860	2015	2300	2480	2840
H3	70	70	80	80	80	80	80	80	80	80	86	86
H	1220	1400	1590	1790	1995	2045	2245	2295	2450	2735	2921	3280
TARE WEIGHT (Kg) FOR JACKETED TANK	644	715	966	1090	1422	1819	1989	2477	2599	3636	4104	4854
TARE WEIGHT (Kg) FOR UNJACKETED TANK	452	493	654	722	932	1234	1329	1719	1819	2526	2864	3314
NOZZLE												
GROSS VOL. (LTRS.)	160	250	500	630	1000	1600	2000	2500	3000	4000	5000	6300
M	500	500	500	500	500	500	500	500	500	500	500	500
N1	80	80	80	80	80	80	80	80	80	80	80	80
N2,N4	50	50	50	50	50	50	50	50	50	50	50	50
N3	100	100	100	100	100	100	100	100	100	100	100	100
N5,N6	-	-	-	-	-	100	100	100	100	100	100	100
L	100	100	100	100	100	100	100	100	100	100	150	150
N11	40	40	50	50	50	50	50	50	50	50	80	80
N12	-	-	-	-	-	50	50	50	50	50	80	80
N14	40	40	50	50	50	50	50	50	50	50	80	80
N15	-	-	-	-	-	50	50	50	50	50	80	80
N13,T11	1/2" BSP	1/2" BSP	1/2" BSP	1/2" BSP	1/2" BSP	1/2" BSP	1/2" BSP	1/2" BSP	1/2" BSP	1/2" BSP	1/2" BSP	1/2" BSP

Standard sizes: 1000-5000 Ltrs. (DIN 28019)

- » Standard production with manhole DN 500 on the top head and outlet nozzle on the bottom head. Operating nozzles on manhole cover and bottom head. Jacketed construction is also available on request, a construction in accordance with DIN standards, as indicated in the tables in the catalog, is also a normal feature of production.
- » In addition, special forms of construction involving either particular dimensions or shapes or both, can be produced to client's specifications.

Support system:

- » Legs; support ring, brackets or skirt are also available on request.



MSGL HORIZONTAL STORAGE TANK



- » Standard sizes: 1000-5000 Ltrs. (DIN 28018/28019)
- » Standard production with manhole DIN 500 and outlet nozzle on the cylindrical part.
- » Operating nozzles on manhole cover and shell side.
- » Support system: Ms saddles.

**Bromine Application
without bottom outlet
with sump for liquid collection
and PTFE lined Dip-pipe**

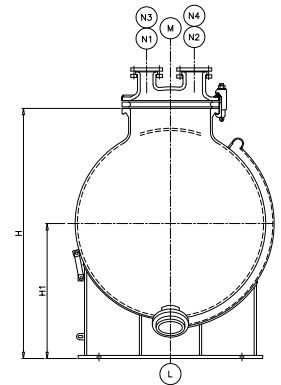
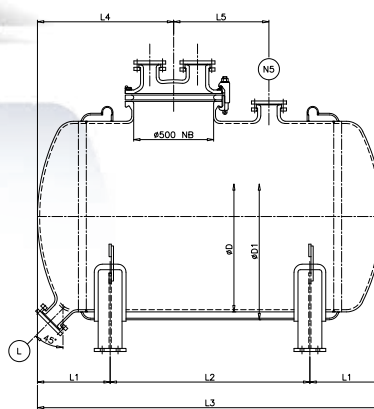

MSGL UNJACKETED / JACKETED HORIZONTAL TANK

GROSS VOLUME (LTRS.)	1000	1600	2000	2500	3000	4000	5000
TOTAL VOLUME (LTRS.)	1240	1740	2145	2650	3390	4355	5835
ØD	1000	1200	1200	1400	1400	1600	1800
ØD1	1100	1300	1300	1500	1500	1700	1900
L1	400	450	450	500	500	600	700
L2	1000	900	1275	1000	1520	1300	1275
L3	1800	1800	2175	2000	2520	2500	2675
L4	750	800	800	850	850	900	950
L5	-	-	500	550	600	550	550
~TARE WEIGHT (Kg)	880	1020	1700	1420	2250	2650	3400
NOZZLE							
GROSS VOLUME (LTRS.)	1000	1600	2000	2500	3000	4000	5000
M	500	500	500	500	500	500	500
N1	80	80	80	80	80	80	80
N2,N4	50	50	50	50	50	50	50
N3	100	100	100	100	100	100	100
N5	-	-	100	100	100	100	100
L	100	100	100	100	100	100	100

MSGL COLUMNS

- » Glass-lined columns are used in chemical plants for rectification, extraction, absorption, sedimentation, and other different types of reactions.
- » Designed and manufactured as per customer's specification.
- » Glass lined columns in jacketed and unjacketed construction are produced in various sections with flanged couplings and clamps for larger diameters. Internal components like support rings, perforated plates, feeders, distributors are also available on request.

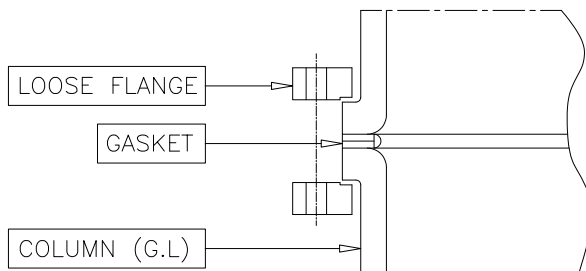

MSGL COLUMN (UNJACKETED / JACKETED)			
DN	L Max	L1 Max	Assembly
100	1000	-	
200	1500	-	
250	1500	-	With Split Flange
300	2000	500	
350	2000	500	

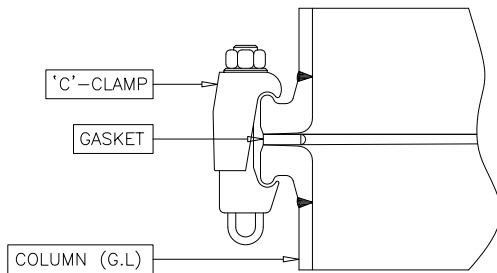

MSGL COLUMN (UNJACKETED / JACKETED)			
DN	L Max	L1 Max	Assembly
400	2000	750	
450	2000	750	
500	2000	750	
600	2000	1000	
750	2500	1500	With "C" Clamp
800	2500	2000	
900	2500	2000	
1000	3000	2000	
1200	3000	2000	
1400	3000	2000	

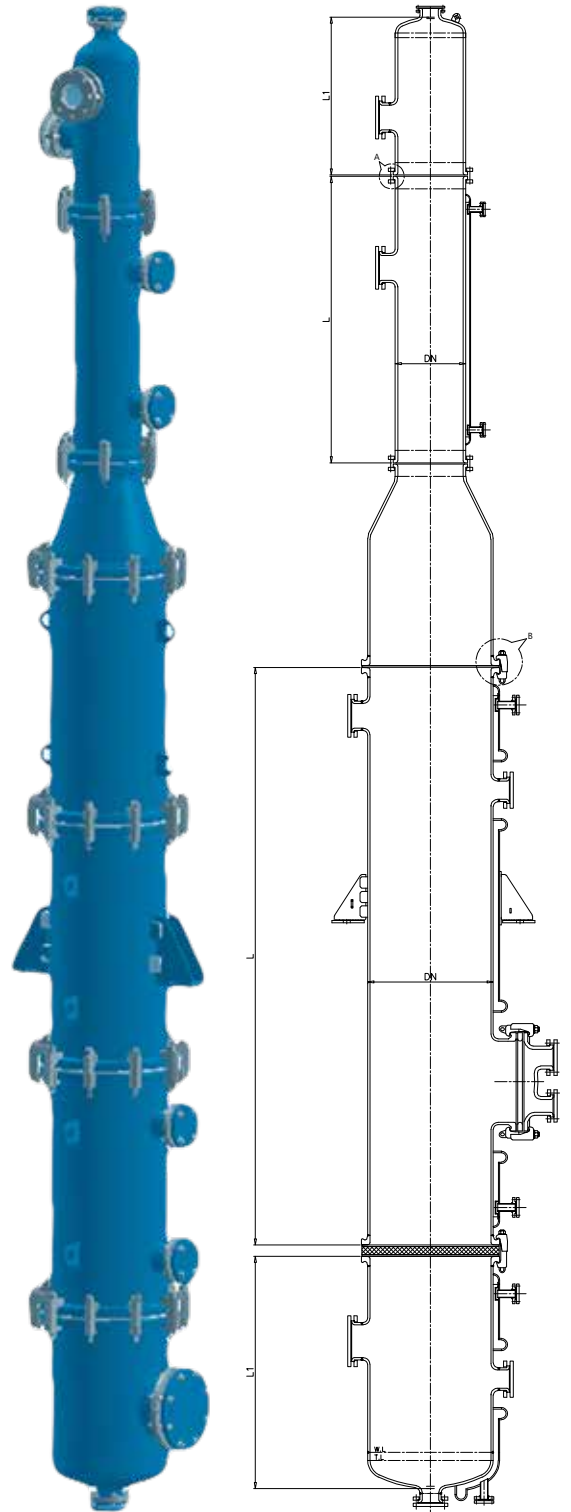

SHELL IN SHELL HEAT EXCHANGER (2 to 20 Sq.m)

- » Standard sizes: 2-20 sq.mt.
- » The double - body type with jacket Heat Exchanger is made up of four concentric bodies providing three distinct sections particularly suitable for heat exchange processes involving a phase change. In the central section (surfaces glass - lined internally and externally), the corrosive product circulates, whilst in the inner and outer sections the heating and cooling fluid circulates. Special types of construction and different dimensions can be provided according to plant requirements

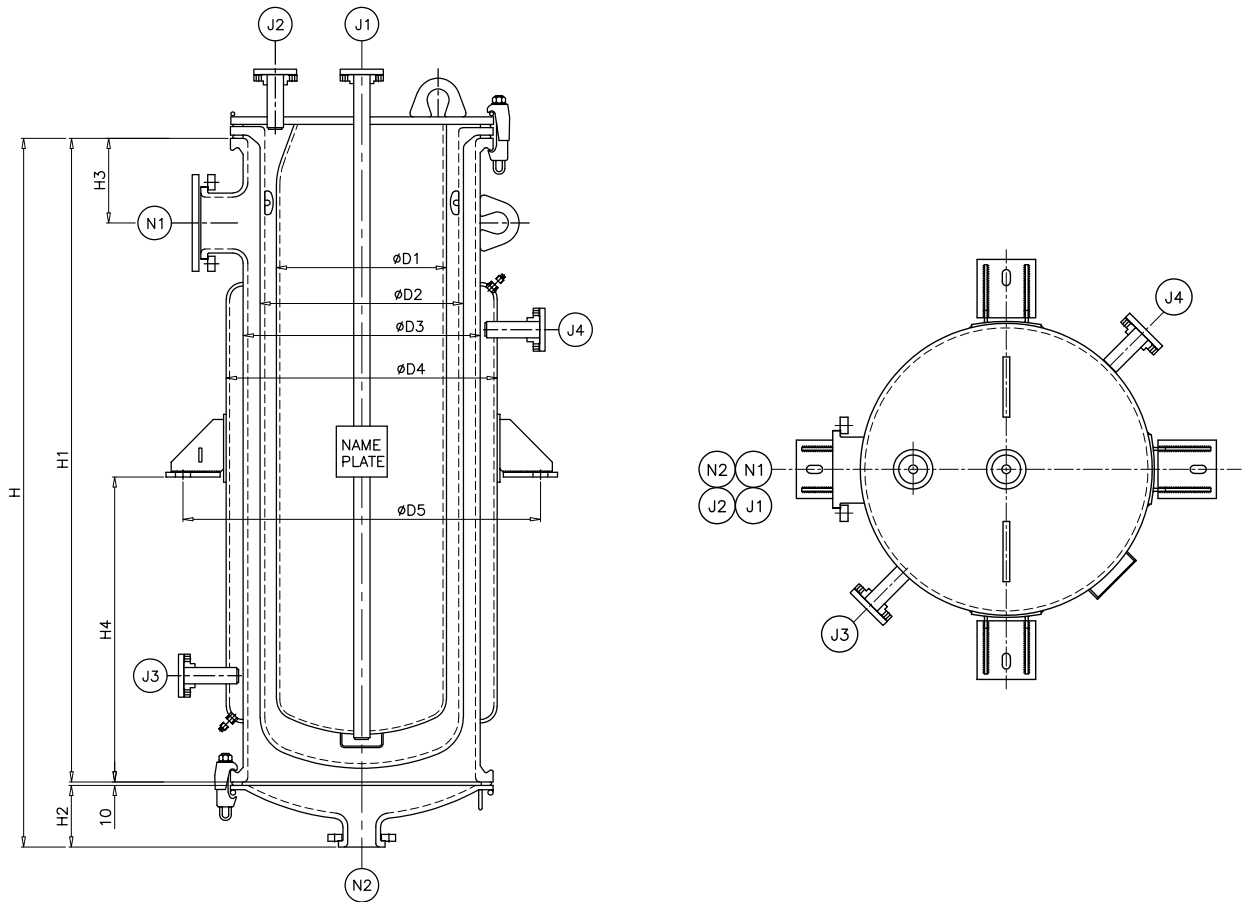

DIMENSIONS

AREA (Sq.Mtr.)	ØD1	ØD2	ØD3	ØD4	ØD5	H1	H2	H3	H4	H	N1	N2	J1	J2	J3	J4	APPX. WT
2	219.1	323.8	406.4	508	674	1150	140	200	450	1300	100	50	25	25	25	25	550
4	400	500	600	700	956	1600	160	250	850	1770	150	50	25	25	25	25	1000
6	500	600	700	800	1055	1900	182	250	900	2092	150	80	40	40	40	40	1500
8	650	750	850	950	1230	2050	200	275	1050	2260	200	80	50	50	50	50	2010
10	650	750	850	950	1230	2450	200	275	1450	2660	200	80	50	50	50	50	2330
12	800	900	1000	1100	1380	2485	225	325	1300	2720	250	80	50	50	50	50	3190
14	900	1000	1100	1200	1480	2500	235	325	1300	2745	250	80	50	50	50	50	3700
16	1000	1100	1200	1300	1580	2700	265	325	1400	2975	250	80	50	50	50	50	4070
20	1100	1200	1300	1400	1680	3010	300	375	1400	3320	300	100	50	50	50	50	5500

GLASSLINED FLUSH BOTTOM OUTLET VALVE (CS/SS)

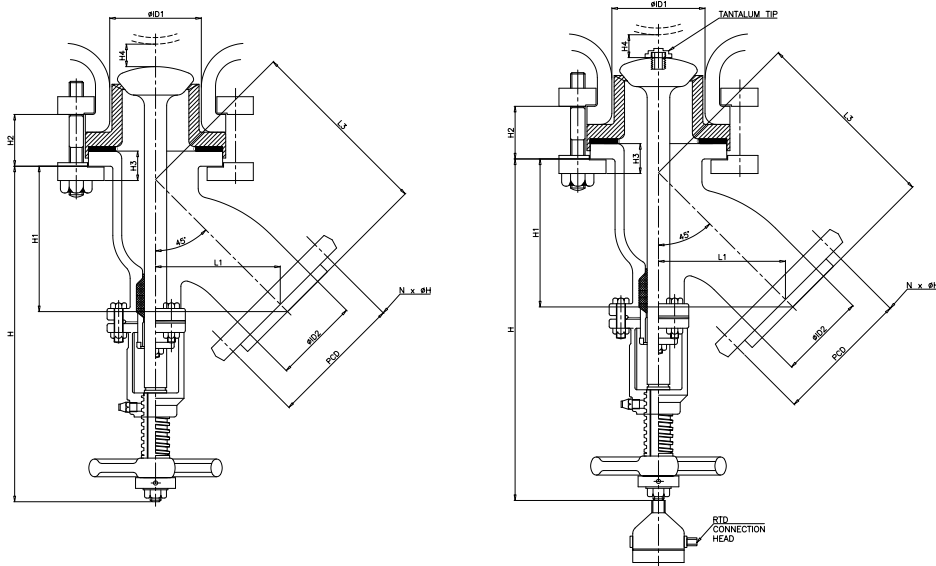

SIZE	ØID1	ØID2	A°	B	C	D	H1	H2	L1	L2	PCD	N x Ø
80 x 50	80	50	45°	191	40	16	381	26	156	130	121	4 x 18
100 x 80	100	76	45°	210	43	32	393	25	180	150	152	4 x 18
150 x 100	150	100	45°	270	45	40	450	25	231	191	180	8 x 18

BELLOW SEALED & ACTUATED FBOV

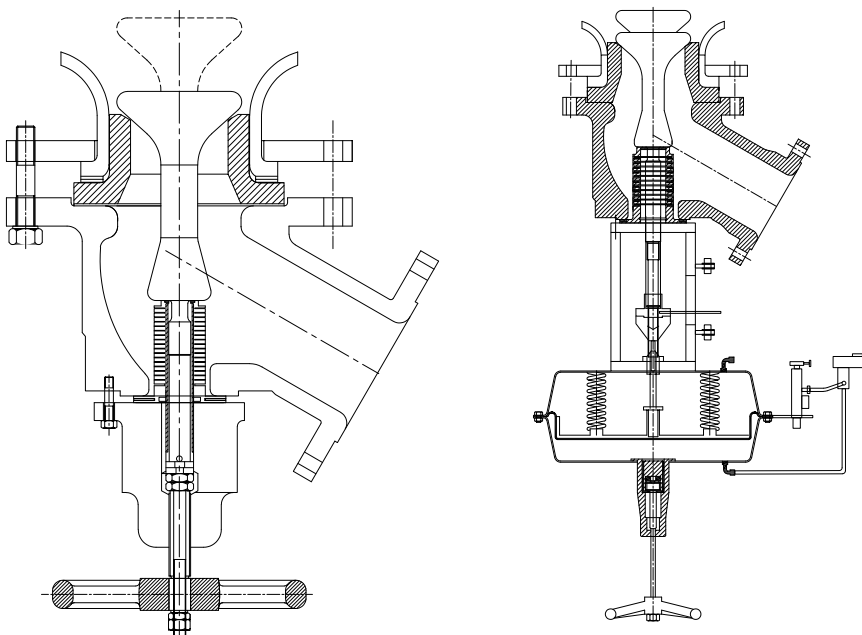

- » Ceracoats bellow - sealed & Actuated valve gives more safety to the users and guarantees a long service life.
- » No dead space in the body neck due to bellow displacement.
- » Optimal adjustable sealing between bellow and spindle head.

AVAILABLE IN SIZE

80X50 NB
100 X 80 NB
150 X 100 NB

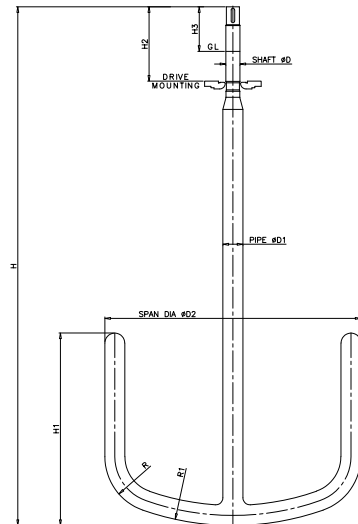
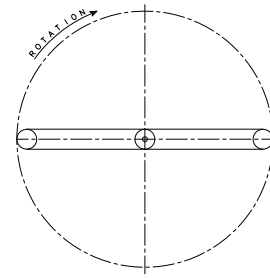

GLASS LINED ANCHOR AGITATOR

CAPACITY (LTRS.)	VESSEL OD	ØD (SHAFT DIA)	ØD1 (PIPE OD)	ØD2 (SPAN DIA)	H1	H2	H3	H	R	R1
63	508	40	60.3	420	220	247	172	885	70	470
100	508	40	60.3	420	320	247	172	1085	70	470
160	800	50	73.3	670	360	318	176	1220	180	730
250	800	50	73.3	670	459	318	176	1405	180	730
500	1000	60	73.3	880	500	312	172	1520	270	950
630	1000	60	73.3	880	660	312	172	1675	270	950
1000	1200	60	88.9	1060	790	312	172	1930	270	950
1600	1400	80	114.3	1250	940	432	266	2300	345	1340
2000	1400	80	114.3	1250	940	432	266	2500	345	1340
2500	1600	80	114.3	1440	1080	432	266	2555	345	1540
3000	1600	80	114.3	1440	1080	432	266	2710	345	1540
4000	1800	100	141.3	1630	1220	515	315	3125	400	1735
5000	1800	100	141.3	1630	1220	515	315	3525	400	1735
	2000	100	141.3	1810	1100	515	315	3165	400	1735
6300	2000	100	141.3	1810	1360	515	315	3665	400	1735

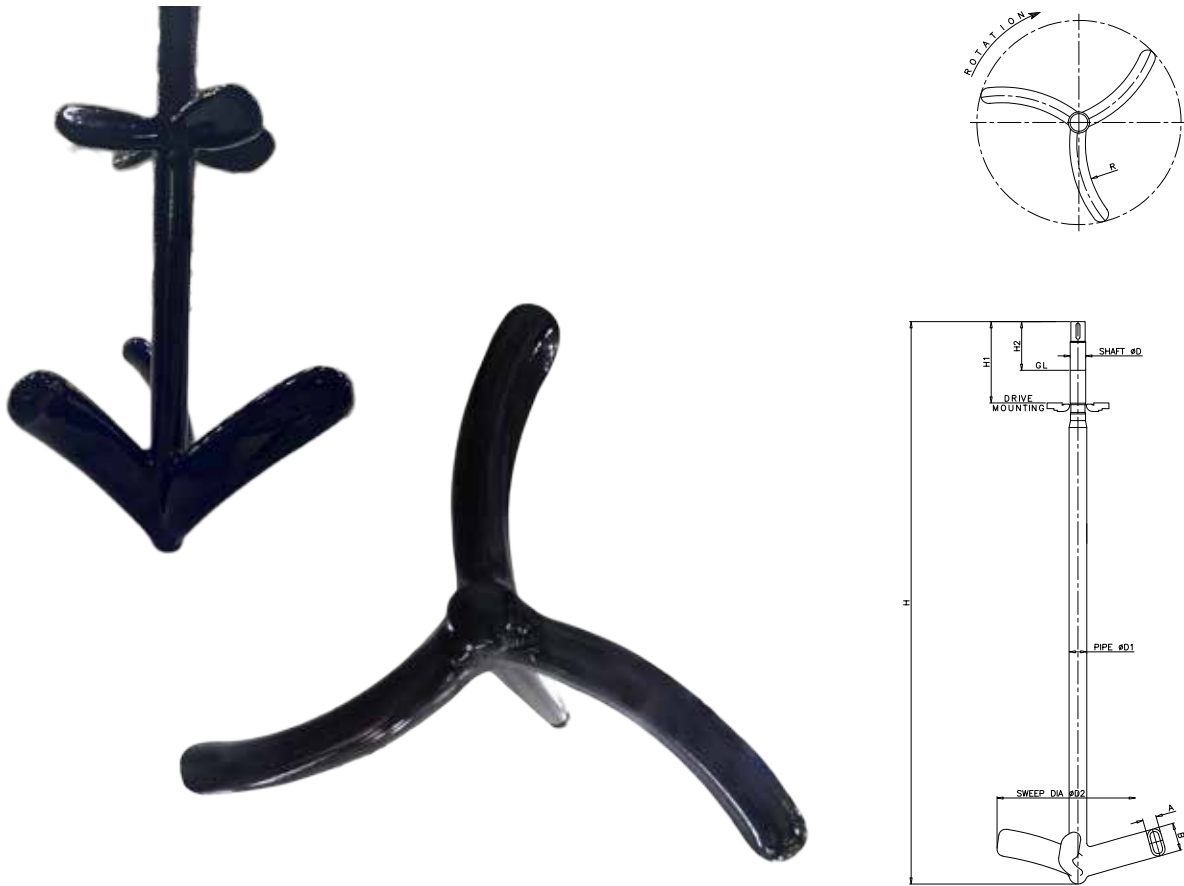

GLASS LINED IMPELLER AGITATOR

CAPACITY (LTRS.)	VESSEL OD	ØD (SHAFT DIA)	ØD1 (PIPE OD)	ØD2 (SWEEP DIA)	H1	H2	H	R	A	B
63	508	40	60.3	300	247	172	880	150	28	60
100	508	40	60.3	300	247	172	1080	150	28	60
160	800	50	73.3	480	318	176	1185	300	43	95
250	800	50	73.3	480	318	176	1397	300	43	95
500	1000	60	73.3	600	312	172	1500	300	43	95
630	1000	60	73.3	600	312	172	1655	300	43	95
1000	1200	60	73.3	720	312	172	1913	450	43	95
1600	1400	80	88.9	840	432	266	2285	450	70	140
2000	1400	80	88.9	840	432	266	2485	450	70	140
2500	1600	80	88.9	960	432	266	2540	450	70	140
3000	1600	80	88.9	960	432	266	2695	450	70	140
4000	1800	100	114.3	1100	515	315	3115	600	85	170
5000	1800	100	114.3	1100	515	315	3515	600	85	170
	2000	100	114.3	1100	515	315	3115	600	85	170
6300	2000	100	114.3	1100	515	315	3635	600	85	170
8000	2200	100	114.3	1100	515	315	3785	600	85	170
10000	2400	125	141.3	1300	605	375	4040	600	85	170
12500	2400	125	141.3	1300	605	375	4640	600	85	170
16000	2800	140	168.3	1500	605	375	4685	600	85	170
20000	2800	140	168.3	1500	605	375	5265	600	85	170

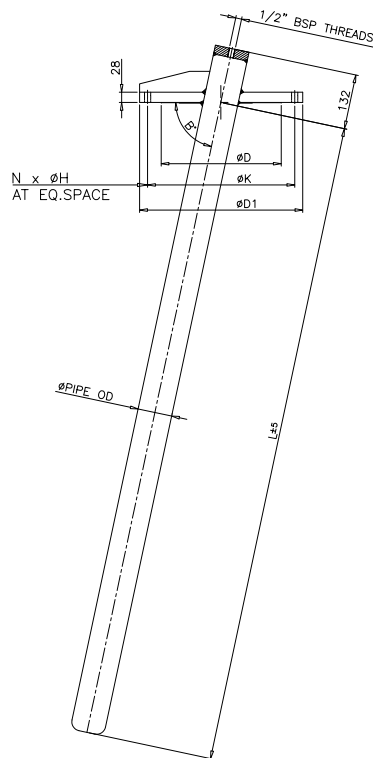

STRAIGHT THERMOWELL

CAPACITY	NOZZLE	ØD	ØK	ØD1	ØPIPE OD	B°	N	ØH	L
IMPELLER									
63	50	100	125	165	33.4	90°	4	18	500
100	50	100	125	165	33.4	90°	4	18	730
ANCHOR									
63	80	138	160	200	33.4	90°	8	18	435
100	80	138	160	200	33.4	95°	8	18	630
160	80	138	160	200	48.3	90°	8	18	648
250	80	138	160	200	48.3	90°	8	18	810
500	100	158	180	220	60.3	90°	8	18	851
630	100	158	180	220	60.3	90°	8	18	1015
1000	200	268	295	340	60.3	78°	8	22	1275
1600	200	268	295	340	73.0	78°	8	22	1480
2000	200	268	295	340	73.0	78°	8	22	1680
2500	200	268	295	340	73.0	78°	8	22	1725
3000	200	268	295	340	73.0	78°	8	22	1880
4000	250	320	350	395	88.9	78°	12	22	2075
5000	250	320	350	395	88.9	78°	12	22	2200
6300	250	320	350	395	88.9	78°	12	22	2590
8000	300	370	400	445	88.9	78°	12	22	2600
10000	300	370	400	445	114.3	78°	12	22	2700
12500	300	370	400	445	114.3	80°	12	22	3290

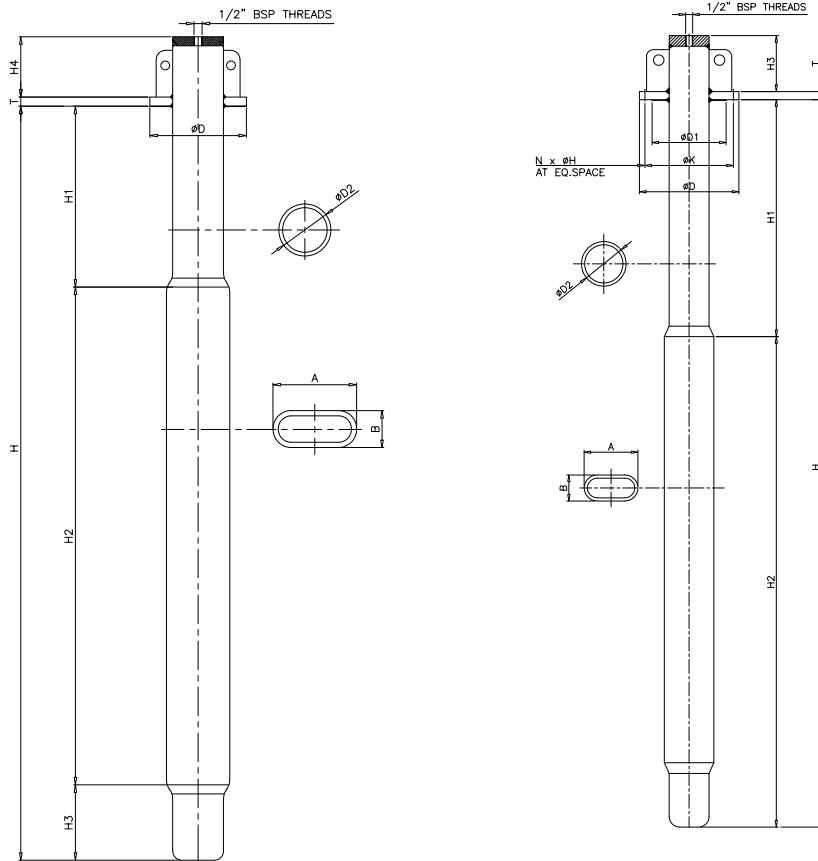

TOP MOUNTED BAT TYPE BAFFLE

CAPACITY	NOZZLE	H1	H2	H	H3	ØD	ØK	ØD1	ØPIPE OD	N	ØH
AE-500	100	480	540	1020	160	158	180	220	73.0	8	18
AE-630	100	480	690	1170	160	158	180	220	73.0	8	18
AE-1000	100	480	920	1400	160	158	180	220	73.0	8	18
AE-1600	100	550	1050	1600	160	158	180	220	73.0	8	18
CE-1600	100	480	920	1400	160	158	180	220	73.0	8	18
AE-2000	100	550	1270	1820	160	158	180	220	73.0	8	18
CE-2000	100	550	1050	1600	160	158	180	220	73.0	8	18
AE-2500	100	550	1270	1820	160	158	180	220	73.0	8	18
CE-2500	100	550	1050	1600	160	158	180	220	73.0	8	18
AE-3000	100	640	1330	1970	160	158	180	220	73.0	8	18
CE-3000	100	550	1210	1760	160	158	180	340	73.0	8	18
AE-4000	150	640	1510	2150	160	212	240	285	114.3	8	22
CE-4000	150	550	1470	2020	160	212	240	285	114.3	8	22
AE/CE-5000	150	550	1470	2020	160	212	240	285	114.3	8	22
AE/CE-6300	150	550	1985	2535	160	212	240	285	114.3	8	22
CE-8000	150	485	2065	2550	160	212	240	285	114.3	8	22
CE-10000	250	600	1900	2500	200	320	350	395	168.3	12	22
CE-12500	250	850	2250	3100	200	320	350	395	168.3	12	22
CE-16000	300	800	2300	3100	200	370	400	445	168.3	12	22
CE-20000	300	800	2900	3700	200	370	400	445	168.3	12	22
CE-25000	300	800	3200	4000	200	370	400	445	168.3	12	22

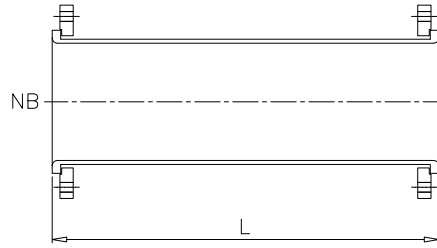

GLASSED STEEL STRAIGHT PIPE															
NB	mm	25	32	40	50	65	80	100	125	150	200	250	300	350	400
	INCH	1"	1 1/4"	1 1/2"	2"	2 1/2"	3"	4"	5"	6"	8"	10"	12"	14"	16"
LENGTH	MIN.	100	100	100	100	100	100	100	150	150	150	150	150	150	150
	MAX.	600	600	600	600	600	1000	1000	1000	1500	1500	1500	2000	2000	2000

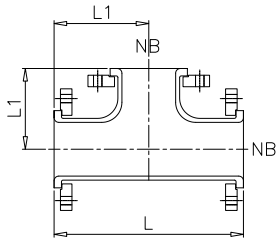

GLASSED STEEL EQUAL TEE																
NB	mm	25	32	40	50	65	80	100	125	150	200	250	300	400	500	
	INCH	1"	1 1/4"	1 1/2"	2"	2 1/2"	3"	4"	5"	6"	8"	10"	12"	16"	20"	
L		180	200	210	230	240	270	310	350	390	520	630	700	900	1100	
L1		90	100	105	115	120	135	155	175	195	260	315	350	450	550	

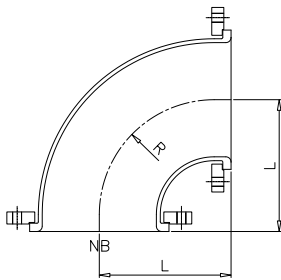

GLASSED STEEL 90° ELBOW															
NB	mm	25	32	40	50	65	80	100	125	150	200	250	300	400	
	INCH	1"	1 1/4"	1 1/2"	2"	2 1/2"	3"	4"	5"	6"	8"	10"	12"	16"	
LENGTH (L)		90	100	105	115	120	135	155	175	195	260	315	350	450	
RADIUS (R)		63	73	78	88	95	115	101	127	152	203	255	305	406	

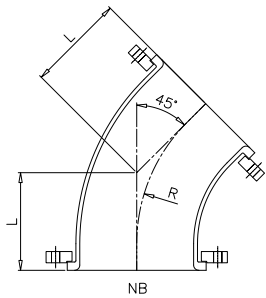

GLASSED STEEL 45° ELBOW															
NB	mm	25	32	40	50	65	80	100	125	150	200	250	300	400	500
	INCH	1"	1 1/4"	1 1/2"	2"	2 1/2"	3"	4"	5"	6"	8"	10"	12"	16"	20"
LENGTH (L)		60	65	70	80	85	95	105	125	150	180	220	260	300	360
RADIUS (R)		63	73	78	88	95	115	152	190	228	305	381	457	610	762

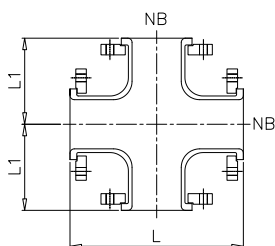

GLASSED STEEL EQUAL CROSS																
NB	mm	25	32	40	50	65	80	100	125	150	200	250	300	400	500	
	INCH	1"	1 1/4"	1 1/2"	2"	2 1/2"	3"	4"	5"	6"	8"	10"	12"	16"	20"	
L		180	200	210	230	240	270	310	350	390	520	630	700	900	1100	
L1		90	100	105	115	120	135	155	175	195	260	315	350	450	550	

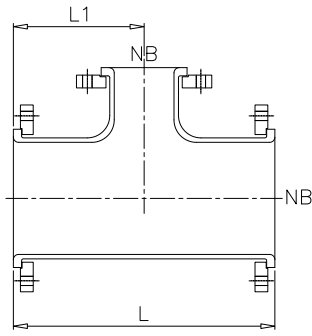

GLASSED STEEL UNEQUAL TEE															
NB			NB1	25	32	40	50	65	80	100	125	150	200	250	
MM	INCH	L		1"	1¼"	1½"	2"	2½"	3"	4"	5"	6"	8"	10"	
32	1¼"	200	L1	95											
40	1½"	210		95	100										
50	2"	230		100	105	110									
65	2½"	240		105	110	115	120								
80	3"	270		115	120	125	130	135							
100	4"	310		125	130	135	140	145	150						
125	5"	350		140	145	150	155	160	165	170					
150	6"	390		155	160	165	170	175	180	185	190				
200	8"	520		185	190	195	200	205	210	215	220	225			
250	10"	630		230	235	240	245	250	255	260	265	270	275		
300	12"	700		220	225	230	235	240	245	255	260	270	310	330	
400	16"	900		270	275	280	285	290	295	305	310	320	360	380	
500	20"	1100		320	325	330	335	340	345	355	360	370	410	430	

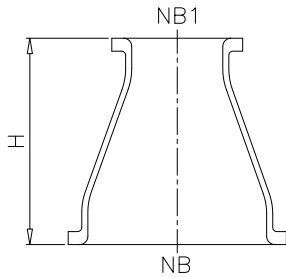

GLASSED STEEL REDUCER																			
NB			NB1	25	32	40	50	65	80	100	125	150	200	250	300	350	400		
MM	INCH			1"	1¼"	1½"	2"	2½"	3"	4"	5"	6"	8"	10"	12"	14"	16"		
32	1¼"	I	L1	140															
40	1½"			140															
50	2"			140															
65	2½"			150															
80	3"			160															
100	4"			175															
125	5"			200															
150	6"			225															
200	8"			250															
250	10"			300															
300	12"			350															
350	14"			410															
400	16"			450															
500	20"			550															

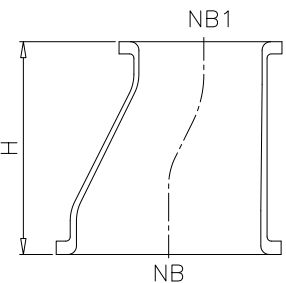

REDUCING FLANGE													
NB	NB1	25	32	40	50	65	80	100	125	150	200	250	
MM	INCH	1"	1¼"	1½"	2"	2½"	3"	4"	5"	6"	8"	10"	
32	1¼"	L1	35										
40	1½"		35										
50	2"		35										
65	2½"		35										
80	3"		35										
100	4"		45										
125	5"		45										
150	6"		45										
200	8"		45										
250	10"		45										
300	12"		45										

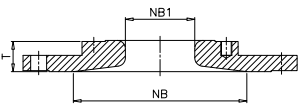

MIXING PATTERNS OF AGITATOR



ANCHOR MIXERS

Anchor mixers feature that are designed to fit close to the tank walls. This design allows the anchor to pull material from the wall surface and maintain agitation with primarily radial flow and medium-high shear. Anchor are ideal for high viscosity products, including cosmetics, pharmaceuticals, chemical and many more food related products.

IMPELLERS

The flow passages and angles of the impeller vanes direct the product from the center of the tank to the outer walls, producing highly efficient agitation and high shear mixing. impellers are ideal for use in sanitary stainless steel tanks for medium-high shear mixing of low- to medium-viscosity materials. They can be used in single and multiphase mixing of liquid-liquid, liquid-solid, and gas-liquid blends.



PITCH BLADE

Ideal for viscous mixtures and for applications requiring a combination of pumping and shearing.

CBRT BLADE

Ideal for applications where shear is the primary requirement, or where agitation close to the bottom of the tank is desired.

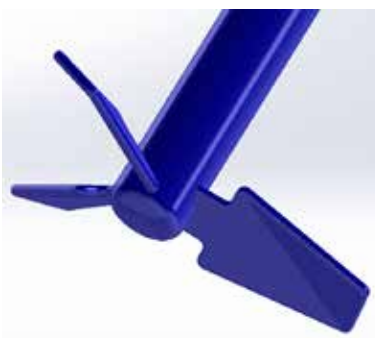

HYDROFOIL

Generally most efficient because it produces the maximum pumping with the lowest shear.

TYPES OF AGITATOR THEIR APPLICATION & FLOW PATTERN

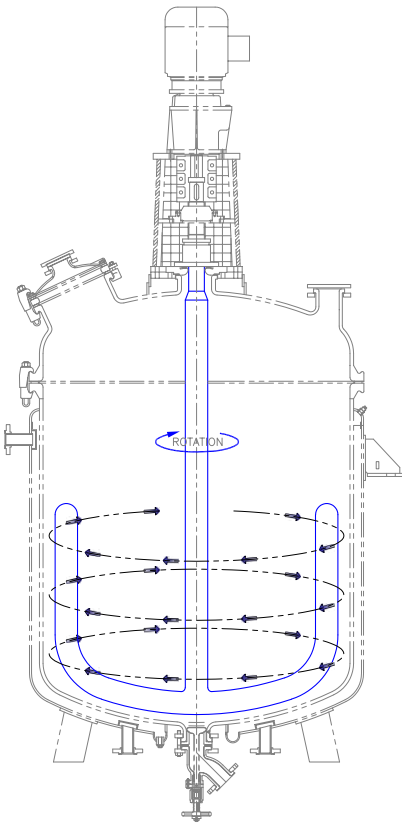

	Heat Transfer	Blending	Suspension	Emulsion	Gas Dispersion
ANC Anchor	√	√	√		
RCI Retreat Curve Impeller	√	√	√	√	
MFI Multi-Flight Impeller	√	√		√	√
PBT Pitched Blade Turbine	√		√	√	
CBT Curved Blade Turbine	√	√	√		√
TBF Turbofoil	√	√	√		
FBT Flat Blade Turbine	√	√	√		√

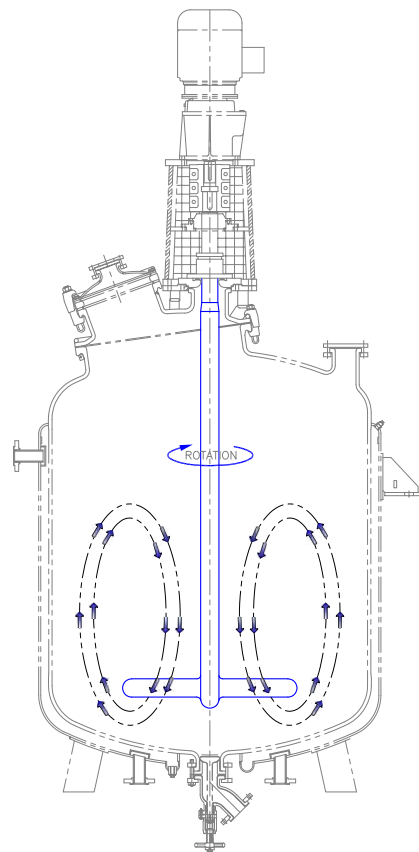
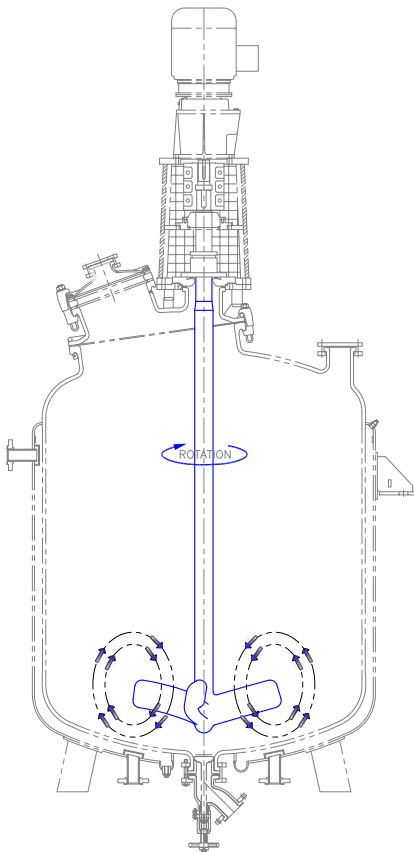

ABOUT GLASS LINING & TYPES

- » Glass is endowed with sui generis combo of corrosion resistance, Chemical inertness, impact resistance, Thermal shock resistance, Non-Adherence and Heat Transfer efficiency in addition to superb Non-catalytic qualities that gives it a position of one of the best material capable of meeting any kind of process needs.
- » Glass offers complete protection against corrosion across the entire pH range and exhibits excellent mechanical properties.
- » It doesn't affect Purity, Flavour, Properties, Colors, Odour or any other Aspect of a Product thanks to its Relatively Super insert Nature.

GLASS TYPES, GLASS PROPERTIES AND EQUIPMENT SPECIFICATIONS

- » Ceracoats makes glass that makes sense and a lot of profit for the end user. Over the years, Ceracoats has continuously generated various types of glass formulations with superior strength, quality and performance.



- » **CERA COBALT BLUE (Standard Glass) 9011**
- » **CERA SAPPHIRE BLUE 9012**
- » **CERA CHROME BLUE (For SSGL) 9013**

This glass offers complete protection against corrosion across the entire pH range, with excellent resistance to radii spiralling, allowing easy and safe application on curved and complex surfaces. It also has unique combination of having higher impact, wear resistance with higher thermal conductivity.



- » **CERA PPG (PHARMA GLASS) 9014**

This glass formulation is a specially developed for pharmaceutical industry. Over and above the standard blue glass this has some outstanding features as under: Light blue colour to improve optical monitoring by increased contrast with process fluids. Excellent hydrophilic surface finish due to its siliceous ionic structure which also facilitates ease in inter - batch cleaning. Heavy metal free glass to keep up purity of active ingredients. Improved resistance to alkalis.



- » **CERA WHITE GLASS 9015**

White glass specially developed for photochemical reactions for observing and monitoring changes in fluid colour during reactions.



- » **CERA GREEN GLASS 9016**

A glass formulation that provides exceptional resistance to extraordinary high temperatures Up to 270°C

CORROSION RESISTANCE

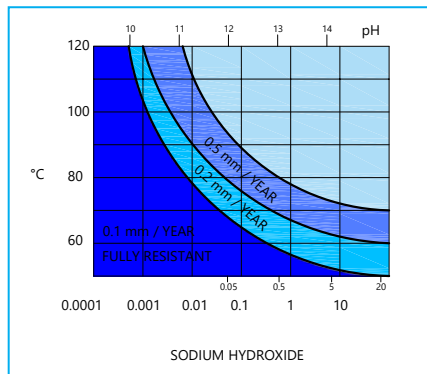
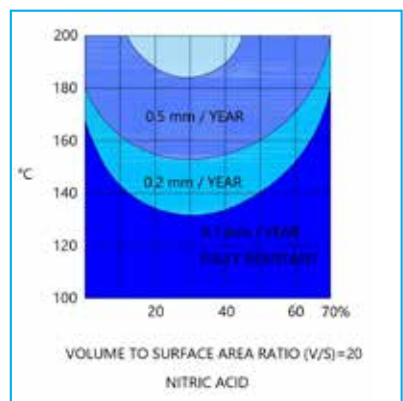
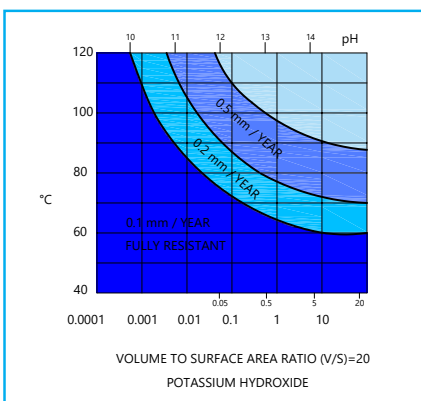
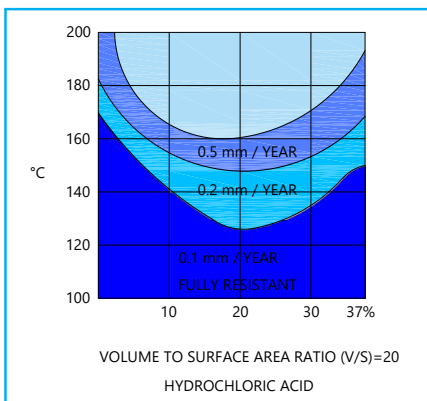
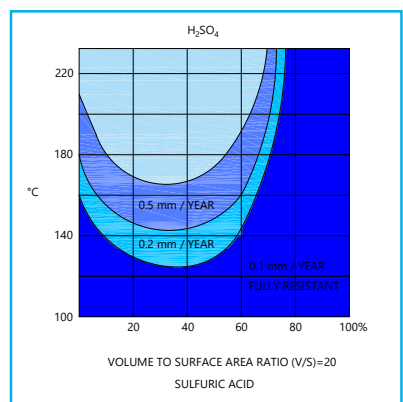
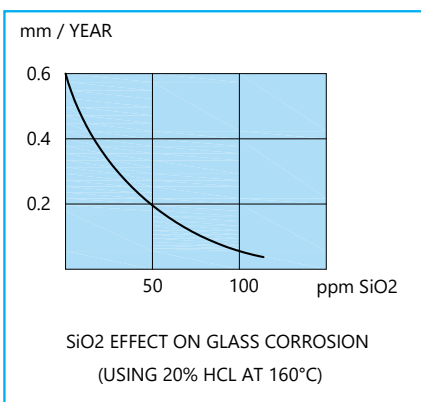
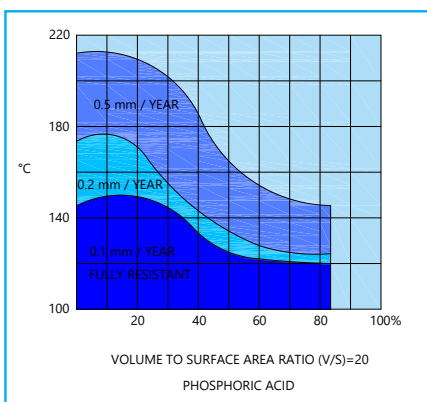
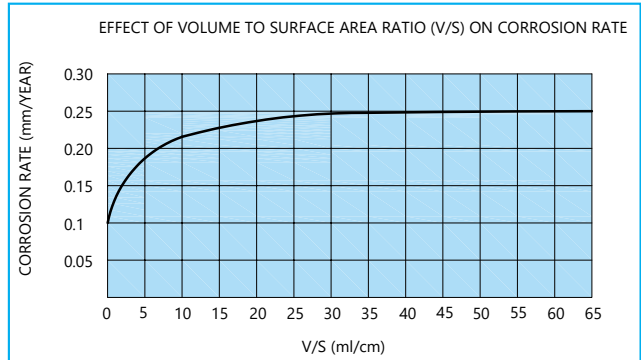
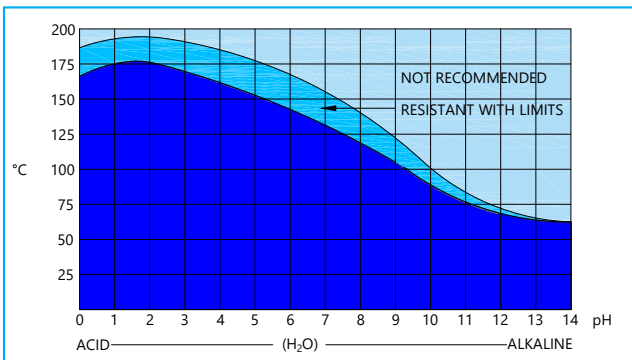

PHYSICAL CHARACTERISTICS

Thickness	: 1~2 mm
Specific weight	: 2.5 g/cm ³
Tensile strength	: 70 N/mm ²
Compressive strength	: 800 N/mm ²
Hardness HV	: 700 kg/mm ²
Thermal conductivity	: 1.2 W/mk
Specific heat	: 0.82 KJ/Kg K
Electric resistivity	: 1013 Ω/cm at ambient temperature
Dielectric strength	: 20-30 kV/mm
Modulus of elasticity	: 75000 N/mm ²
Elongation	: 0.1%
Abrasion	: 3.5 mg/min
Flexibility	: Lined glass bends with the base metal until reaches permanent deformation.
Chipping tendency	: None, Under normal conditions.
Surface	: Exceptionally smooth, hence easier to Clean, excellent resistance to wear, Impermeable to gases, prevents sticking And the growth of microflora. Biologically Easily sterilisable
Chemical resistance	: Highly resistance to almost all substances. Insensitive to the action of oxidizing or Reducing agents. No catalytic effect. No Product contamination. (i.e. of colour, smell, Taste, etc.)
Structural	: Dielectric in nature, hence no electro- Chemical corrosion. It does not age as it is Amorphous in structure and does not Weather.

GLASS FRIT AND TESTING STANDARD FOR LABORATORY:

- DIN EN ISO 28706: Resistance to Chemical Corrosion Acids, Neutral Liquid & Alkalis as Application.
- DIN EN ISO 28721: Quality Requirement (Part-1)
- DIN EN ISO 28721: Thermal shock and Impact Resistance (Part-3)
- DIN EN ISO 15695: Scratch and Abrasion Resistance

MECHANICAL RESISTANCE

MECHANICAL PROPERTIES

Glass has the disadvantages of brittleness and low tensile strength. One remedy is to place the glass lining under compression. This is achieved during cooling of the glassed item after firing. This is caused by the difference between the coefficients of thermal expansion of the glass and the base metal and the excellent bond between them.

If the glass steel composite is subjected to a mechanical strain due to handling, mechanical or thermal shock, the compressive stress must not be overcome before putting the glass into tension, causing it to fail. Therefore, the residual compressive stress in the glass acts as an effective shock absorber.

ABRASION

Abrasion of the glass lining is simply a wearing away of the glass abrasive solids in the reactor. It is characterized by a loss of fire polish and in severe cases, a rough sandpaper-like finish.

Experience has shown that failure due to abrasion alone is very uncommon. In combination with acid corrosion, however, failure can be quite severe: abrasion weakens the silica net-work mechanically allowing acid corrosion to accelerate.

CERA 9011 (Cobalt Blue) has good resistance to abrasion as well as better physical characteristics such as mechanical shock, impact resistance, thermal shock resistance etc.

CHEMICAL RESISTANCE

The type of Corrosive substance along with the Temperature determines the effect of concentration. Concentrated acids are less corrosive than diluted acids with the exception of Phosphoric Acid.

Different factors, such as the type of corrosive substance, its Concentration, pH, Temperature and Agitational forces affect the rate of corrosion.

SUBSTANCE

Ceracoats (CERA 9011-Cobalt Blue) provides a high degree of resistance to Acids, Bases, Solvents, Gases, Uncondensed Vapors, Melted Salts of Acidic, Natural or Anhydrous Nature, at Relatively high Temperature and at all Concentration.

TEMPERATURE

Temperature has a strong effect on corrosion for both acids and bases. Generally, the rate of corrosion for bases double with every 10°C increases in temperature. at pH 14 (NaOH) the maximum permissible limits are 57°C.

Time of exposure also plays significant role in process. the effect of exposure time on corrosion varies, depending upon the nature of corrosive substance. In case of acids when the time of exposure is increased the rate of corrosion tends to diminish. Bases however, display a constant corrosion rate with time.

ACIDS

CERA 9011 (Cobalt Blue) exhibits excellent resistance to all acids - organic and inorganic, oxidizing and reducing. The iso corrosion curves are established for most common acids. Reagent grade acids are used in laboratory test that produced these curves. In actual practice other factors such as velocity, phase type, chemical grade etc can affect the corrosion rate.

Only hydrofluoric acid causes rapid destruction of Glass Lining at all concentrations. When phosphoric acid concentration is increased, it becomes more aggressive towards glass. At 85% concentration the maximum useable temperature is 95°C.

BASES

Bases are of more corrosive nature than acids. As concentration increases rate of corrosion increases. Also, the rate of corrosion increases with increase in temperature. An increase of 10% doubles the rate of attack of Glass Lining. Therefore, it is important to be cautious while using hot alkalis.

WATER

Water can cause severe corrosion which increases with water purity. Our CERA 9011 is competent enough to combat corrosion in vapor phase environment. Condensed water droplet on the colder surface of the glass in vapor phase, tend to leach out the alkali ion from the glass network. Therefore, it is recommended that the vessel contents be slightly acidic. It also recommends that Unjacketed top dish be insulated to reduce condensation.

EFFECT OF HYDROFLUORIC ACID ON GLASS

It is well known that hydrofluoric acid (HF) will completely destroy Glass Lined Vessel. Even at concentration as low as 20ppm, fluorides in acid environment have a devastating effect on Glass surface, specifically in continuous reactions where the fluoride as HF are repeatedly replenished. Hydrofluoric acid reacts with silicon dioxide main ingredient in glass, destroying the SiO₂ structure and producing a rough surface.

Preventing fluorides attack on Glass Lined surface requires constant vigilance by the users. Reactants which can contain fluoride impurities must be carefully analysed to determine the fluoride level before they are used. In particular technical grade phosphoric acid and its salts are often fluoride contaminated and other mineral acids.

CORROSION INHIBITION

Chemical reactions are sometimes so severe that they cause a rapid wear of glass lining. The use of additives to the reacting substances can inhibit this corrosion permitting the use of glass-lined equipment. When using acids, several hundred ppm of silica protects the glass lining and considerably reduce the rate of corrosion in liquid phase. Refer figure 3. The same result can be obtained in vapour stage by adding silicon oils. Generally, the higher the temperature, the greater the quantity of silica required and the more concentrated the acids are, the less silica needs to be used. In presence of fluorine, silica also has a favourable influence. Refer figure 4. With alkalis, a few hundred ppm of calcium, aluminium or zinc may reduce corrosion, especially in dilute solutions.

THERMAL SHOCK RESISTANCE

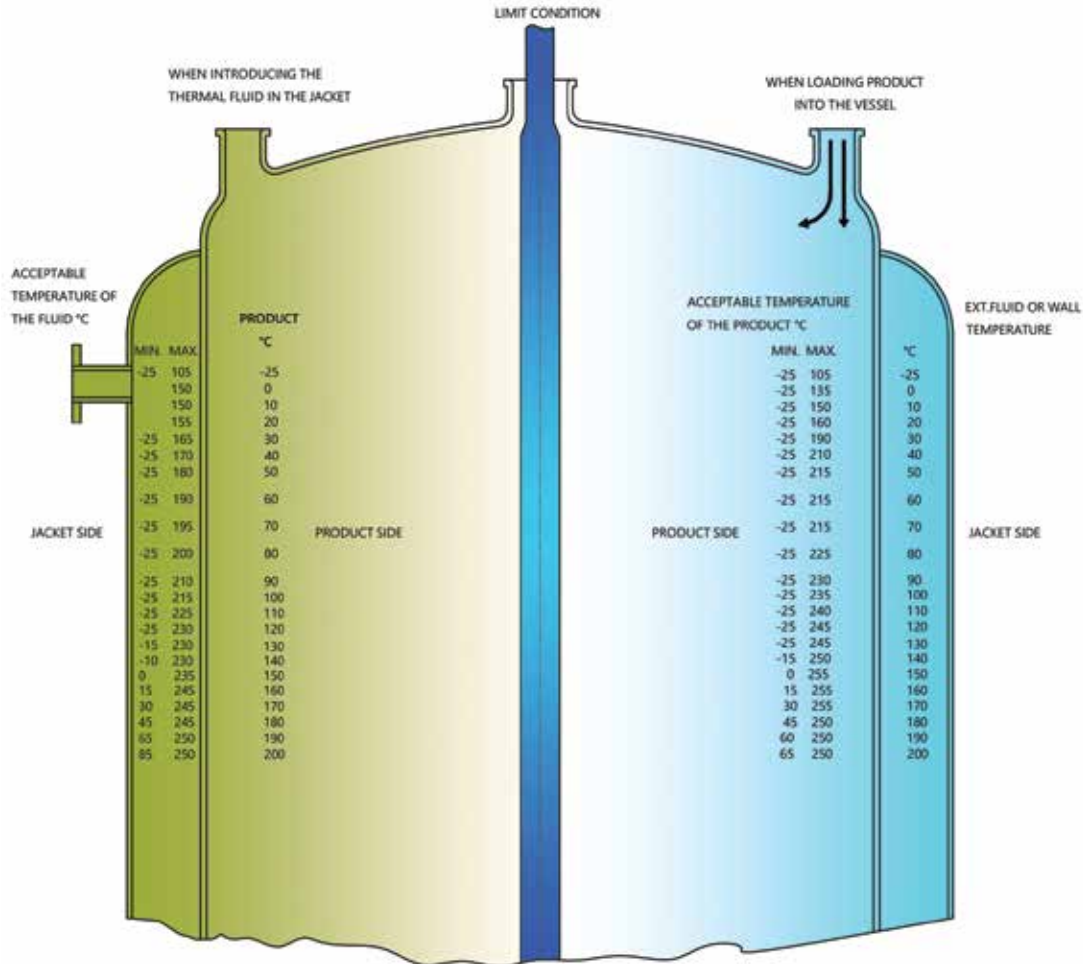

Any sudden temperature change on either glass or jacket side can result in damage to the Glass Lining and should be avoided. Most damaging thermal shocks are caused by splashing of cold products on to a hot glass surface. This causes formations of fine surface cracks which lead to Glass Lining failure. Most thermal shock damage results in flaking of the lining in relatively small but thick pieces of glass with a characteristic shape.

Guideline for maximum allowable temperature differences are given in adjoining figure 6. The left half of the chart gives maximum & minimum temperature of fluids which are introduced in the jacket for various temperature of fluids which are introduced in the jacket for various temperature

of products in the reactor. e.g. if the temp. of product & the glass wall is 140°C, the temp. of fluid introduced in jacket should be between -15°C & 255°C.

The right half of the figure gives maximum & minimum temp. of products which are changed in the reactor for various temperature of glass and heating / cooling fluid in the jacket. e.g. if the temp. of jacket fluid & the glass wall is 180°C, the temp. of product charged in reactor should be between 50°C & 255°C.

However, for safe use of the equipment, 80% of figures given in the table should be used as a guideline.

THERMAL CONDUCTIVITY

Steel allows the glass lining to be kept relatively thin compared to self-supporting glass equipment. Thus, the low thermal conductivity of the glass is counter-balanced by the high heat transfer coefficient of the steel. Due to the chemical bond between glass and steel, no interface heat transfer resistance needs to be taken into account.

Overall Heat Transfer Coefficient (U) W / m K			
Fluid in jacket		Fluid in vessel	U
Heating	Steam	Organic liquid	345 ~ 469
		Aqueous liquid	403 ~ 520
	Oil	Organic liquid	192 ~ 269
		Aqueous liquid	278 ~ 315
Condensing	Water	Organic vapor	155 ~ 180
		Water vapor	178 ~ 219
Cooling	Water	Organic liquid	113 ~ 187
		Aqueous liquid	123 ~ 178
	Brine	Aqueous liquid	74 ~ 145

values of overall heat transfer coefficient for various heating and cooling conditions.

PTFE BUSH



A very well balanced portfolio and good price to quality ratio helps CERACOATS stand out from its competitors and other PTFE manufactures in India. Over the years CERACOATS has bagged orders from top brands across the globe and from top brands operating in the domestic market. one of the top and experienced PTFE manufacturers in India With more than 25 years of experience in the field of ptfе manufacturing in India, CERACOATS is a well-established player known for its high quality and high precision PTFE (Polytetrafluoroethylene) components. it can easily cater to bulk orders in both domestic as well as international markets.

GLASSED STEEL PROTECTION RING

Available in Size
250 NB
350 X 450 NB
500 NB

GLASSED STEEL MANHOLE COVER

Available in Size
250 NB
350 X 450 NB
500 NB

GLASSED STEEL HANDHOLE COVER

Available in Size
150 NB
250 NB



CERACOATS

WE MAKE IT POSSIBLE

MFGR. OF GLASS LINED EQUIPMENTS



Unit-1

C-1,1-53, Phase-IV, GIDC Estate,
V.U.Nagar, Anand
Gujarat - 388121, India

Unit-II

Block No, 833, Rajnagar Road
Khadol, Anand
Gujarat - 388 350, India

MD

TANMAY PATEL
tanmay@ceracoats.net
98252 28948

CHIRAYU PATEL
chirayu@ceracoats.net
98253 28949

Marketing

mkt@ceracoats.net
98254 28948
exports@ceracoats.net

Scan QR Code



Visit Website